

# LM75 Modular Diamond Drill System

### DRILLING DEPTH GUIDELINES

The figures in these tables have been calculated, based on field experiences, and may be reasonably expected. Actual drilling capacity will depend on in-hole tools and conditions, drilling techniques and equipment used.

These variable factors will cause changes to depth obtained. No claim is made for products listed that are not produced by the Boart Longyear Company to perform at these depths.

**Please refer to specifications tables for available thrust, pull and torque to aid in estimating capacities for your specific application.**

	Metric System			U.S. Customary System		
	Hole direction (metres)			Hole direction (feet)		
<b>Coring System</b>	Vertical Up	Horizontal	Vertical Down	Vertical Up	Horizontal	Vertical Down
<b>AQ</b>	610	1310	1700	2000	4300	5580
<b>BQ</b>	450	920	1320	1480	3020	4330
<b>NQ</b>	290	680	1020	950	2230	3350
<b>HQ</b>	160	380	600	525	1250	1970

### Up Hole Drilling (Reverse Feed Frame)

<b>AQ</b>	1190	3900
<b>BQ</b>	870	2850
<b>NQ</b>	590	1930
<b>HQ</b>	360	1180

Rated depths have been based on achieving the following RPM at the bottom of the hole.

System	RPM
AQ	1000
BQ	800
NQ	600
HQ	500

### PRIME MOVER

**Installed Capacity**      standard: 75kW (100 hp) electric motor  
    optional: diesel power units

## TECH DATA

DIAMOND CORE DRILLING

# LM75 Modular Diamond Drill System

HYDROSTATIC PUMPS	Main Pump	Recirculation Pump
<b>Application</b>	All Drill Functions	Oil cooling and charge pump
<b>Type</b>	Variable Displacement Axial Piston with pressure compensated load sensing control.	Gear Fixed displacement
<b>Manufacturer</b>	Rexroth (Hydromatik GmbH)	Rexroth
<b>Operating conditions as used on LM75 drill:</b>		
<b>Maximum pressure</b>	28 MPa (4060 psi) forward rotation, reverse rotation, and rod handling	5 bar (72 psi)
<b>Normal speed</b>	1450 rpm (50 hz) 1750 rpm (60 hz)	1450 rpm (50 hz) 1750 rpm (60 hz)
<b>Hydraulic tank volume</b>	66 L (17.4 U.S. gallons)	

## FEED FRAME

<b>Feed length:</b>	1830 mm (72 in)	
<b>Max. rated pushing force:</b>	61 kN @ 28 MPa (13,420 lbf @ 4060 psi)	
<b>Max. rated pulling force:</b>	123.4 kN @ 28 MPa	(27,148 lbf @ 4060 psi)
<b>Rated carriage speed:</b>	0.70 m/sec (3 ft/sec) for one complete cycle	
<b>Normal rod handling speed:</b>	Approx. 15 m/min (50 ft/min) Actual rod handling time may vary with working conditions.	

**NOTE:** Feed Frame is reversible.

CHUCK AND ROD HOLDER	HQ Chuck	PQ Rod Holder
<b>Maximum opening</b>	97.0 mm (3.82 in) diameter corresponding to the ID of the HQ guide bushing.	125 mm (4.875 in) diameter corresponding to the ID of the PQ guide bushing.
<b>Type</b>	Closed hydraulically Opened mechanically Automatic synchronization with rod holder	Closed mechanically Opened hydraulically Automatic synchronization with chuck Manual override
<b>Jaws: Quantity</b>	3	3 (same as used in chuck)
<b>Type</b>	Tungsten carbide inserts	
<b>Max. rated ▼ axial holding capacity</b>	Forward and Reverse rotation 85.0 kN * (19,110 lbf) *	130 kN * (33,750 lbf) *
<b>Max. rated ▼ static torsional holding capacity</b>	3900 Nm * (2870 lbf ft) *	5800 Nm * (4255 lbf ft) *

▼ at 7 MPa (1015 psi)

\* with new jaws and rods

## LM75 Modular Diamond Drill System

**HQ DRILL HEAD**

Chuck speed	Forward	Reverse
	0–1350 RPM Continuously adjustable. Speeds will vary with oil type and temperature, and are only approximate.	100 RPM Fixed to help prevent rod thread damage.

Chuck output torque	Forward	Reverse
	325 Nm (239 lbft) at 1250 RPM 900 Nm (662 lbft) at 500 RPM	3750 Nm (2765 lbft) at 28 MPa (4060 psi) with break-out device

**Dynamometer Produced Chuck Output Curve**

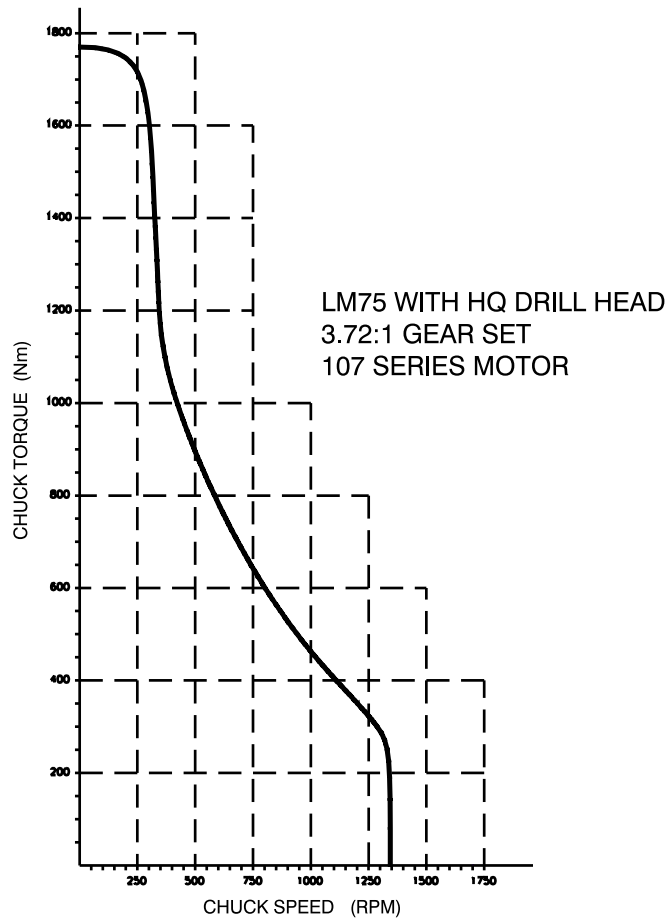

## TECH DATA

DIAMOND CORE DRILLING

# LM75 Modular Diamond Drill System

### DIMENSIONS AND WEIGHTS

#### Feed Frame

Weight: 1364 kg (3000 lb)

Includes:

#### Rotation Unit c/w Chuck

Weight: 234 kg (515 lb)

and

#### Rod Clamp Assembly

Weight: 155 kg (340 lb)

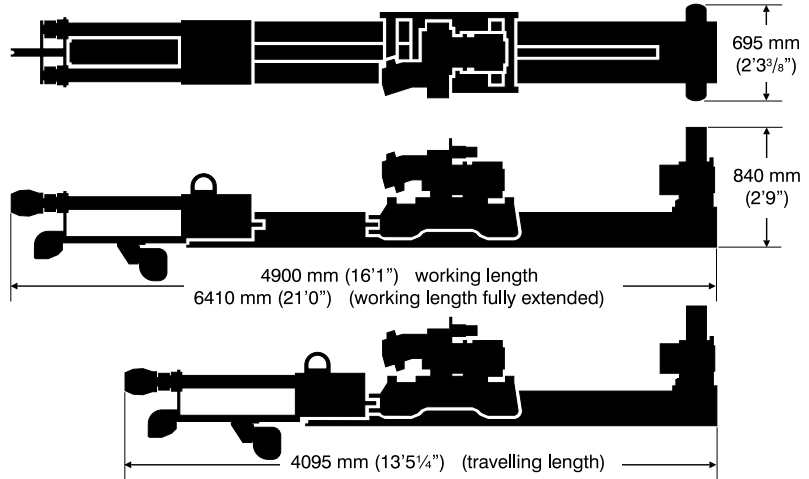

#### Power Pack

Weight: 1190 kg (2620 lb)  
without towing group

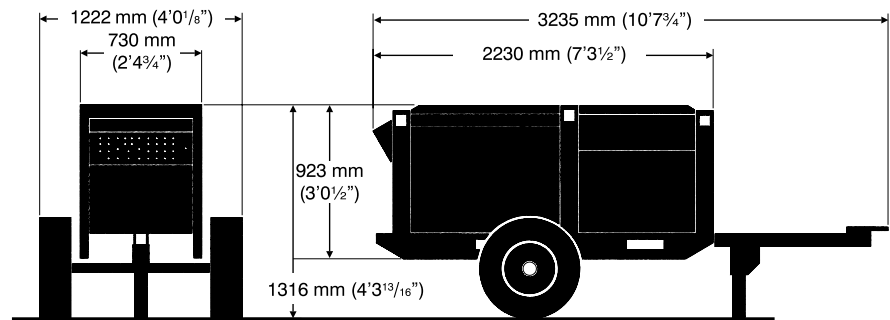

#### Control Panel

Weight: 46 kg (101 lb)  
without hoses.

Add 42 kg (92 lb) for hoses.

